

WHERE WERE THE VICTIMS IN RELATION TO THE PLANE

WRONG
PLACEMENT OF
VICTIMS ON
RIGHT
SIDE OF PLANE

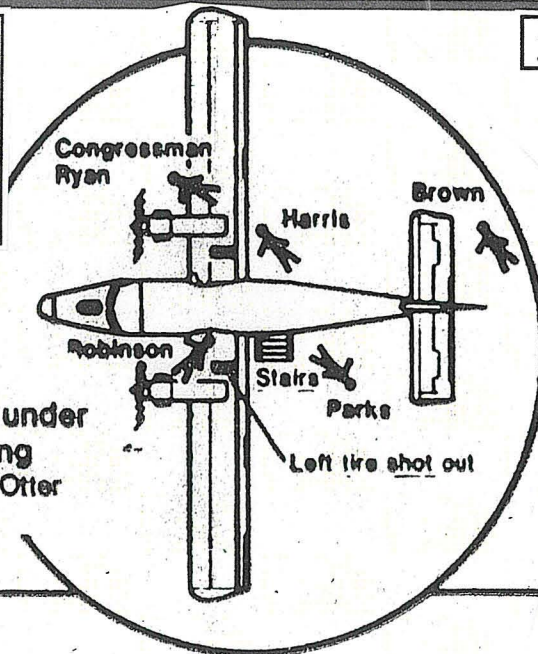

Victims around and under aircraft after shooting de Havilland DHC-6 Twin Otter (Seats 18-20)

Copyright, 1978 San Francisco Examiner

This *inset* from The Reiterman Schematic shows the plane placed **BACKWARDS**, incorrectly placing the victims on the plane's **RIGHT** side. (Note: The Reiterman Schematic proper shows the correct placement, with the attack being launched opposite the passengers' boarding area on the **LEFT** side of the plane.) **LET'S NOW FIX THIS WITH ON-SITE PHOTOS FROM NBC.**

2



Passengers Amassing Boarding Area on **LEFT** side of the Plane

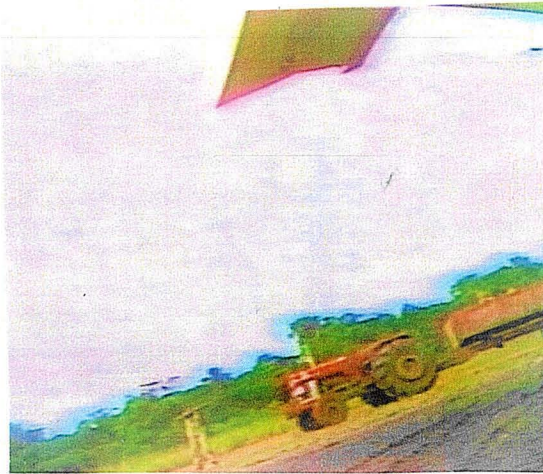

NBC Cameraman Bob Brown filming between **LEFT** wing of plane and overhanging propeller.

3 'Brown stayed on his feet, kept filming as attackers advanced'

By RON JAVERS
Copyright San Francisco Chronicle

SAN JUAN, Puerto Rico (AP) — Jonestown is every evil thing that everybody thought — and worse.

The slaughter began at 4:20 p.m. Saturday (Guyana time) while we were standing beside the twin-engine airplane that had brought us to Port Kaituma, seven miles outside Jonestown, on Friday and that had returned to pick us up.

I was waiting between Bob Brown and Don Harris, the two NBC men who were killed. We had become close friends during the course of our ordeal.

The firing erupted from guns close by: I was hit first. I was

knocked to the ground by a slug in the left shoulder, apparently from a .38-caliber weapon.

I crawled behind the right wheel of the plane.

Bob Brown stayed on his feet and kept filming what was happening, even as the attackers advanced on him with their guns.

He was incredibly tenacious. While I was trying to decide whether to stay where I was or risk the 100-yard dash across the close-cropped grass field to the jungle, I saw Brown go down.

Then I saw one of the attackers stick a shotgun right into Brown's face, inches away, if that.

"I was waiting between Brown and Don Harris, the two NBC men who were killed. Bob Brown stayed on his feet and kept filming, even as the attackers advanced on him with their guns."